



Remote Spectrum Monitor

High-Performance RF Spectrum Monitor

MS27201A

9 kHz to 9/20/43.5 GHz



Remote Spectrum Monitor MS27201A

OVERVIEW

Demand for access to the RF spectrum continues to grow at an increasing pace. Alongside new cellular bands, the use of RF spectrum by satellite operators, microwave links, radar, and defense electronics expands each year.

Efficient and effective use of the spectrum by users requires a deep insight into the total radio frequency activity by other users in region. The Remote Spectrum Monitor MS27201A is designed to facilitate wide area spectrum monitoring up to 43.5 GHz. Building on over 40 years' experience in developing high performance field portable spectrum analyzers, the Remote Spectrum Monitor MS27201A series is our highest frequency spectrum monitor covering all standard LMR, cellular, satellite, and defense electronic bands.



Remote Spectrum Monitor MS27201A is Available with 9 kHz to 9, 20 and 43.5 GHz Frequency Range Options

Key Specifications

Parameter	Specification
Frequency Range	9 kHz to 9/20/43.5 GHz
Analysis Bandwidth	110 MHz
Third Order Intercept Point (TOI)	+20 dBm
DANL (with pre amp)	-164 dBm
Amplitude Range	DANL to +30 dBm
Phase Noise @ 1 GHz	-110 dBc/Hz @ 100 kHz offset (typical)
RBW/VBW	1 Hz to 10 MHz
Amplitude Accuracy	< 14 GHz ± 1.3 dB (± 0.5 dB typical)

Key Features

Feature	Specification
Control Interfaces	Ethernet
PC Control	Remote GUI PC application
Automated Monitoring Software	MX280001A Vision monitor PC application
IQ	Capture and streaming IQ data through Ethernet, USB, and PCI interfaces
Cellular Modulation Quality Measurements	LTE and 5GNR
Continuous Operation and Recovery	Built in watchdog timer and auto recover on power failure provide continuity of service
Traces	Six with independent detectors per trace
Markers and Limits	Intelligent markers and comprehensive limits
Event Capture	Save traces and alarms on defined events

Remote Spectrum Monitor MS27201A

Designed for Long Term Monitoring Applications

Compact Rack Mount Format

The Remote Spectrum Monitor MS27201A instruments are standard 19 inch rack wide and 2U tall. They are designed to slot directly into test system racks using minimal space. The instruments are powered from a supplied 75 Watt power block that minimizes rack temperature gain.

High Performance

Typical applications for the Remote Spectrum Monitor MS27201A requires excellent noise floor for signal detection and high TOI to minimize internal distortions when the input is exposed to multiple input signals. With a displayed average noise level (DANL) of -164 dBm and a TOI of typically +20 dBm, signal detection, and measurement integrity are assured. Measurement bandwidths of up to 110 MHz with IQ capture and streaming options provide class leading functionality in a small form factor package.

24/7 Operation

The Remote Spectrum Monitor MS27102A is designed for continuous operation. Recovery features are included to ensure reliable and uninterrupted monitoring. A built-in watchdog timer resets the instrument in the event of a software interruption. Should a break in the power supply occur, when the power is restored the instrument will resume normal operation in the same state it was in prior to loss of power.

IQ Capture and Streaming

The Remote Spectrum Monitor MS27201A provides for the capture of IQ data of signals-of-interest (SOI) for later post processing. When an illicit signal is detected, post capture analysis is performed to identify the source of the signal. The 110 MHz measurement bandwidth enables the captures of transient and continuous signals to internal instrument memory or directly to a mass storage device. Dedicated PCI interfaces provide the bandwidth required for the most demanding cases where real-time streaming is required.

Optional vector signal analysis software MX280005A performs modulation analysis on common digital modulation standards for greater insights.

With the accessory data converter module MA25424A, IQ data can be streamed to the X-COM IQC5000B for mass storage and later analysis with X-COM SpectroX software.

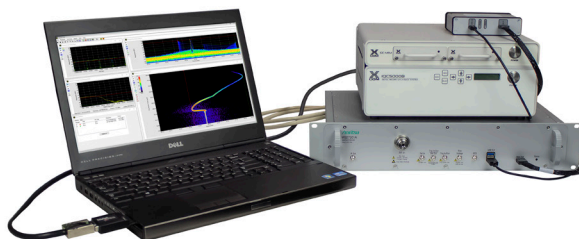

MS27201A Streams IQ Data Directly to the X-COM IQC5000B Record and Playback System

5G NR and LTE Modulation Quality Measurements

Options for 5G and LTE demodulations enables detailed analysis of these common cellular standards. Measurements including base station PCI and bandwidth as well as frequency to facilitate the identification of rogue or illicit transmitters. Coupled with the spectrogram and IQ capture, field technicians have a array of tools to capture and analyze signals in the cellular spectrum.

Distributed Spectrum Monitors with Centralized Control

Connect multiple Remote Spectrum Monitor MS27201A instruments to a network and control them from a single centralized PC.

Remote Spectrum Monitor MS27201A

The remote PC software GUI is able to switch seamlessly between the control of multiple Remote Spectrum Monitor MS27201A instruments. When monitoring the RF spectrum across a wide area, a single PC can configure and control multiple instruments to simplify the operation.

When using MX280001A Vision software, the spectrum traces from multiple Remote Spectrum Monitor MS27201A instruments are displayed on the PC screen providing a quick and clear overview of all activity in the area under surveillance.

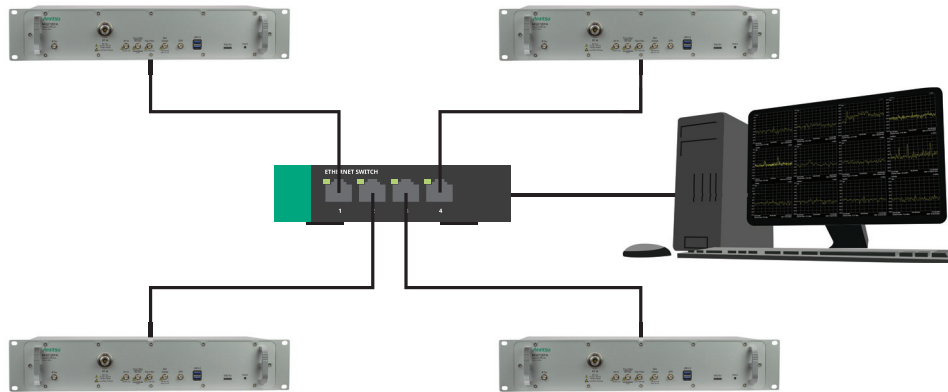

A Single PC can Control Multiple MS27201As on a Common Network

Rich in Features to Enhance Spectrum Monitoring

The Remote Spectrum Monitor MS27201A is packed with all the features required to perform long term spectrum monitoring. In addition to six simultaneous traces, each of which can be configured with a different detector, the Remote Spectrum Monitor MS27201A offers:

- 12 intelligent markers for labeling and identifying signals
- Limit lines with multiple segments and automatic set up around active signals
- Save on events including time interval and mask violation
- Smart measurements to rapidly characterize signals OBW, Channel Power, and spectral emission
- Spectrogram display with time stamps for historic recording
- Record and playback of trace data for analysis of intermittent signals

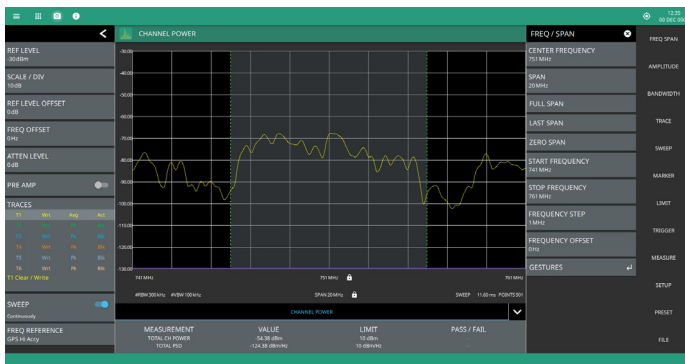

Common Spectrum Analyzer Measurements Including Channel Power are Automated with Smart Measurements

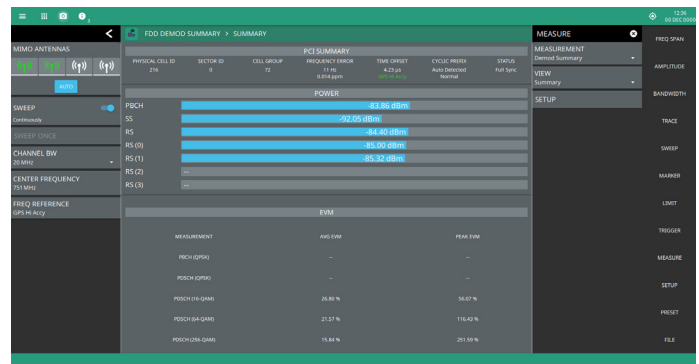

Modulation Measurement Options Perform Modulation Analysis on LTE and 5G Base Station Signals

Remote Spectrum Monitor MS27201A

APPLICATIONS

Spectrum Clearing

Frequency spectrum is typically allocated and policed by a national regulator. Licenses for specific blocks of spectrum are time limited and can change their use as new technologies and applications evolve. When a new license is issued, the new spectrum owner needs to survey the spectrum to confirm legacy users have ceased transmitting. As transmitters may only be active periodically, monitoring the spectrum for a period of days or weeks may be necessary to ensure all legacy users have moved out of the spectrum.

The Vision software option has integrated tools to simplify this spectrum clearing process.

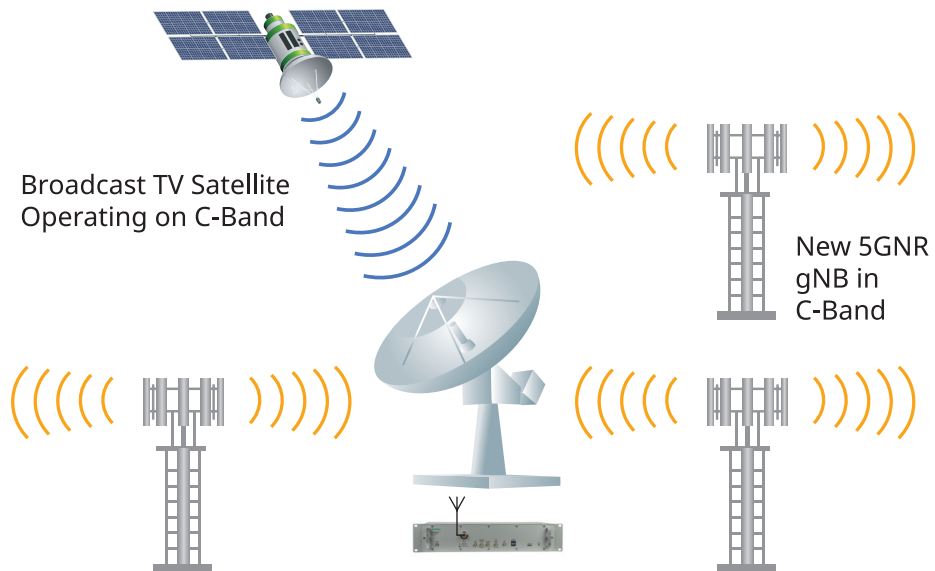

MS27201A Monitoring for Adjacent Channel Interference from New Cellular Base Stations with Legacy Satellite Downlinks

Remote Spectrum Monitor MS27201A

APPLICATIONS (Cont'd)

Shared Spectrum Monitoring

It is becoming increasingly common for more than one technology to be allocated access to the same block of spectrum. Early examples of spectrum sharing is the 3.5 GHz band in the USA where legacy military radars and new commercial cellular networks share the same spectrum. A tiered access regulation manages their co-existence. In order for operators to understand how this will affect their long term ability to provide a service, they need to continuously monitor activity in the spectrum to build up a understanding of likely availability over days and months.

The Remote Spectrum Monitor MS27201A with MX280001A Vision software or custom monitoring applications enables spectrum owners to build up maps of how the spectrum is being used and what access they can expect, depending on their status in any tiered system.

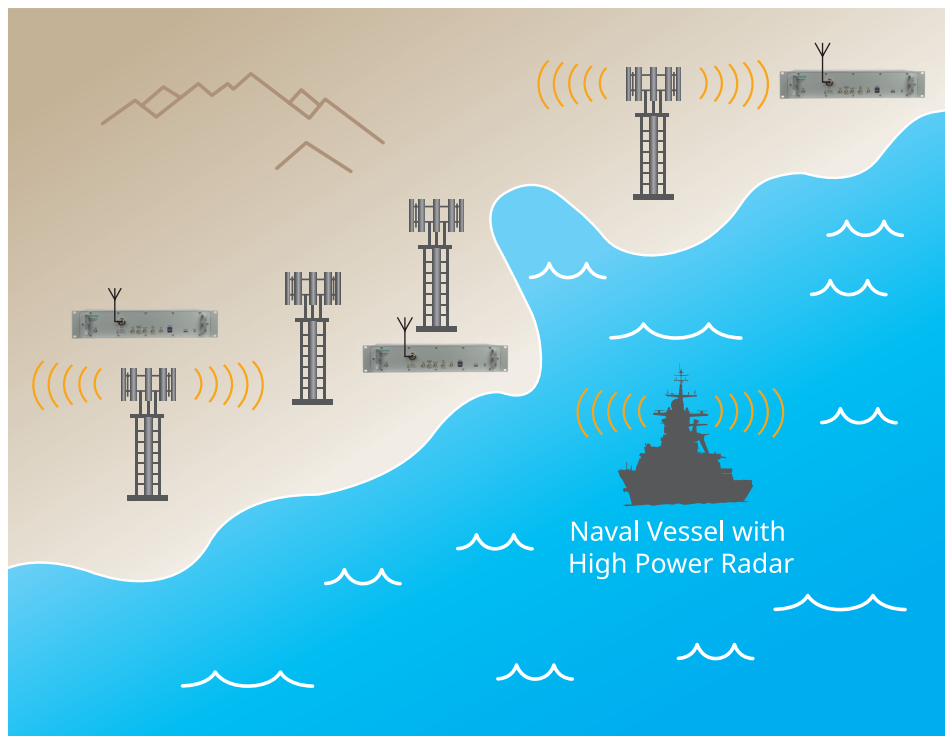

Military Radar and Commercial Communications System often Share the Same Spectrum with Priority Access

Remote Spectrum Monitor MS27201A

APPLICATIONS (Cont'd)

Satellite Ground Station Monitoring

The expansion of satellite services is growing rapidly. Satellites have become ubiquitous providers of communications systems and monitoring of multiple properties of the earth, including weather, light pollution, and heat sources. The proliferation of low earth orbit communications networks and GNSS positioning system has resulted in forecast of thousands of satellites orbiting the earth.

Satellite downlink signals typically arrive at the surface of the earth with very low signal level and the latest generation of satellites are starting to use millimeter-wave (mmWave) frequencies for these downlinks, including 8 to 9 GHz X band for space research, 12 GHz Ku band for domestic TV broadcast and 23 to 27 GHz for fixed link broadcasts.

The sensitivity of satellite downlink receivers make them very susceptible to interfering signals. Continuous monitoring of the in-band and adjacent frequencies is essential to maintain robust communications and understand if and when additional filtering may be required.

At earth stations with multiple dishes, Remote Spectrum Monitor MS27201A instruments can be located at the base of the dish to monitor activity across the site in real time. A single monitor showing the spectrum at each receiver provides a dashboard that alerts operators of potential interference, giving the earliest possible warning of potential communications failure.

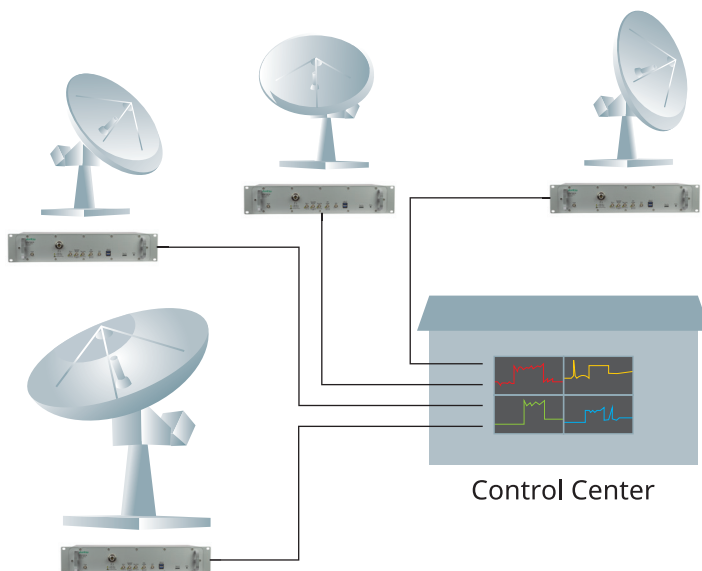

Monitor the Downlink Spectrum from Multiple Ground Stations with a Single PC in the Control Room

Remote Spectrum Monitor MS27201A

APPLICATIONS (Cont'd)

Critical Site Security

Many government defense and commercial sites have experienced aggressive and intentional interference from hostile agents. On-site communications are critical for the smooth running of large sites with many interdependent automated systems. Monitoring and early detection of hostile transmissions is essential to effective site operation. Examples of vulnerable sites include prison services, transport hubs and government offices.

Positioning MS27201A spectrum monitors across a site with broadband spectrum coverage gives the best possible security against such attacks. The measurements from all deployed instruments are routed back to a common control room facilitating monitoring and rapid detection of interfering signals at any location across a site.

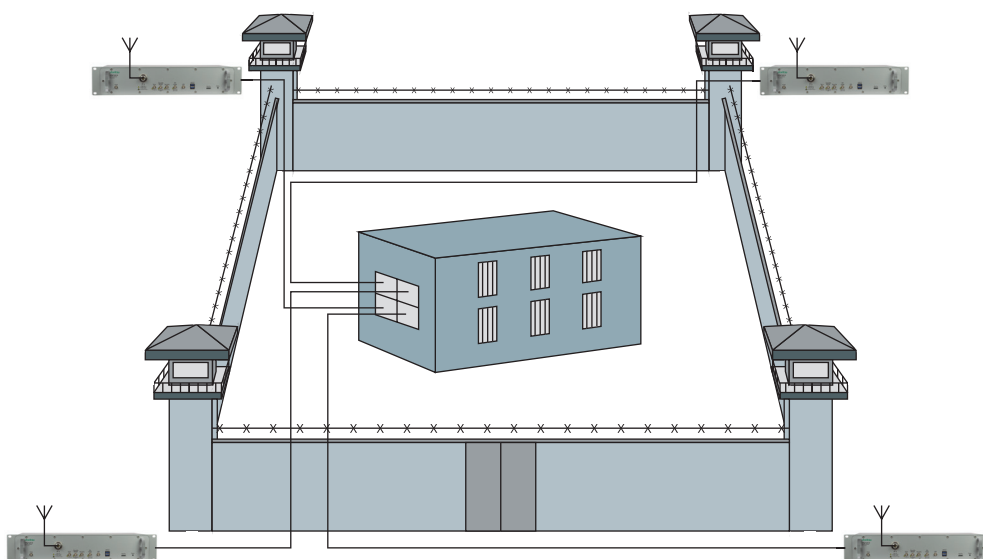

Protect the Integrity of Critical Infrastructure from RF Interference Using Strategically Placed MS27201A Spectrum Monitors

Interference Monitoring

Major sporting events, festivals, and conferences bring together multiple agencies to a single location for maybe only a few days or weeks. Each contributing agency often has unique communications and telematics requirements that require temporary licensing. Typical examples include international motor racing events, football tournaments, and global music festivals. To ensure all the stakeholders' systems are transmitting on their approved frequencies and not interfering requires strict monitoring of the spectrum.

Remote spectrum monitoring MS27201A instruments cover all the frequency allocations that are active at such events such as telematics links, radio microphones, satellite news gathering, and broadcast point-to-point radio links.

Regulatory Enforcement

National regulators need to police spectrum activity in large urban areas. Large cities will have multiple licensed transmitters and unless the spectrum is policed, there will be interference and degraded performance across all systems.

Remote Spectrum Monitor MS27201A

INSTRUMENT CONTROL OPTIONS

The Remote Spectrum Monitor MS27201A can be controlled using customer written PC applications, a downloadable PC Graphical User Interface (GUI), or with the MX280001A Vision Monitor PC software application.

Remote Spectrum Monitor MS27201A PC Software

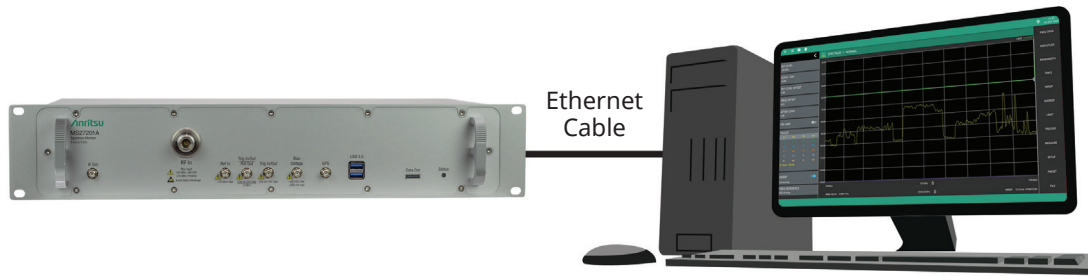

The MS27201A PC Application Provides an Off-the-Shelf GUI for Common Applications

A downloadable PC application provides a comprehensive user interface. Connect to any Remote Spectrum Monitor MS27201A on the same network to take manual control of the instrument, configure measurements, and save results. No special user training is required as the PC GUI is based on the standard Anritsu spectrum analyzer interface. Traces and IQ data are stored directly to the PC memory for ease of later recall and playback functionality. Full screen captures can be saved as well as individual result traces, traces saved by “Save on Event” triggers or traces continuously saved over a defined period of time.

The Remote Spectrum Monitor MS27201A instrument’s PC GUI is ideal for manual configuration and viewing of spectrums when continuous monitoring is not required. All the standard features of a spectrum analyzer are available to capture specific events and save images or trace files directly to the PC memory. Manual real-time configuration of the spectrum monitor allows targeted configurations for detailed signal analysis and investigation.

Remote Spectrum Monitor MS27201A

INSTRUMENT CONTROL OPTIONS (Cont'd)

Remote Spectrum Monitor MX280001A Vision Monitor Software Application

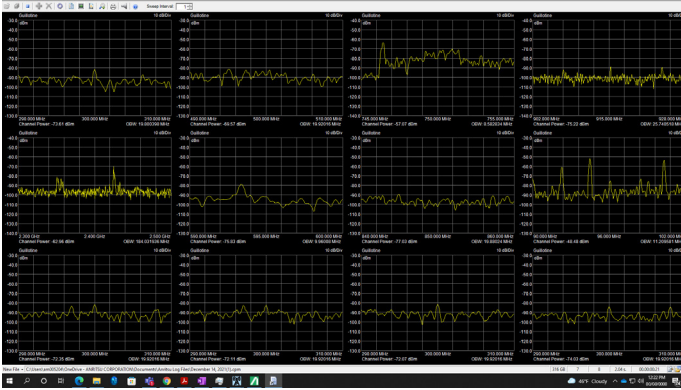

View the Spectrum Traces from Multiple MS27201A on a Single PC Monitor with the Vision High Speed Port Scanner Option

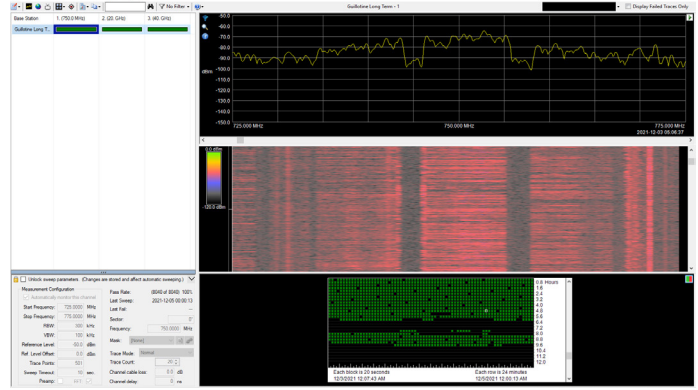

Log Spectrum Traces for Extended Time Periods and Monitor for Interfering Signals with Alarms and Alerts

When long-term monitoring is required, the optional Vision software offers a full suite of spectrum monitoring and trace archiving options.

Vision Monitor software offers a range of applications for monitoring the RF spectrum over a period of time and storing results to a database. Vision Monitor is an ideal tool for long-term interference monitoring. Limits can be set with automated alarms for limit violations to capture short-term or intermittent signals. Other features include a scanner option that enables the monitoring of a range of frequency bands or channels over time with unique settings for each channel being monitored. A multi-trace view shows the spectrum for all channels being monitored on the same display.

The Vision Monitor application is fully automated. Measurements can be captured and periodically uploaded to a database for further processing. Depending on need and storage capacity, users can store spectrum history over many months or years with a user-defined capture assigned schedule.

All spectrum measurement databases are searchable, allowing the user to quickly locate patterns of signal activity relevant to an investigation. The spectrum history can also potentially be used in legal proceedings for documenting illegal or unlicensed broadcast activity. Other functions provided by Vision Monitor include:

- Threshold and trace mask settings for alarm generation
- Email alert sent when threshold violation generates an alarm
- Reporting on spectrum integrity on a daily or weekly basis
- Vision runs on a PC/laptop using the Windows® operating system (Windows 7/8/10)

Remote Spectrum Monitor MS27201A

Remote Spectrum Monitor MS27201A Interfaces

The Remote Spectrum Monitor MS27201A comes standard with: 2 x USB 3.0 type A host ports and a high speed Data Out port. USB ports provide for saving of screen images as a .png, saving IQ data files, IQ data streaming, and facilitate software or option updates. The Data Out port is used for high-speed IQ streaming. Integrated rack mount flanges on the case simplify installation into standard 19 inch rack systems and the low power consumption and air cooling allow for integration immediately adjacent to other instruments maximizing space efficiency.

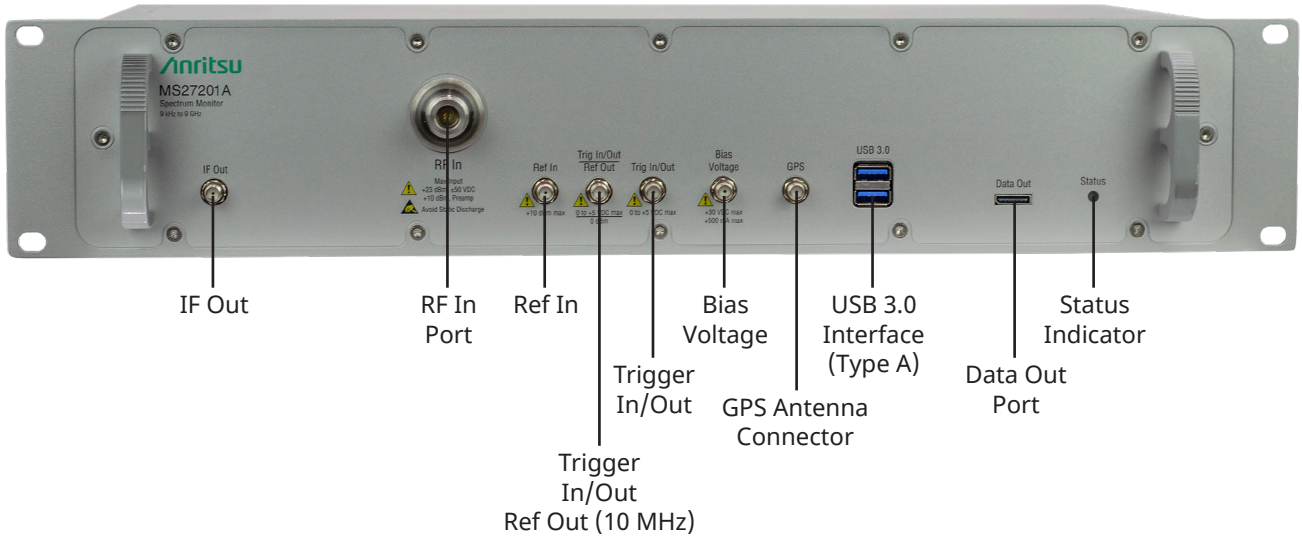

Remote Spectrum Monitor MS27201A

Ordering Information

Part Number	Description
MS27201A	Remote Spectrum Monitor (Requires Option 709, 720, or 743)
Options	
MS27201A-0709	Frequency Range 9 kHz to 9 GHz
MS27201A-0720	Frequency Range 9 kHz to 20 GHz
MS27201A-0743	Frequency Range 9 kHz to 43.5 GHz
MS27201A-0031	GPS Receiver (requires GPS antenna, sold separately)
MS27201A-0089	Zero Span IF Output
MS27201A-0090	Gated Sweep
MS27201A-0104	110 MHz Analysis Bandwidth
MS27201A-0124	IQ Waveform Capture
MS27201A-0125	IQ Waveform Streaming (requires Option 124 recommended)
MS27201A-0126	IQ Waveform Capture (non-export controlled)
MS27201A-0127	IQ Waveform Streaming (non-export controlled, requires Option 126 recommended)
MS27201A-0128	Vector Signal Analysis enabled (requires Option 124 or 126)
MS27201A-0400	Vision Monitor Enabled
MS27201A-0407	Vision High-Speed Port Scanner Enabled
MS27201A-0883	LTE FDD/TDD Measurements (requires GPS Option MS27201A-0031)
MS27201A-0888	5G NR Downlink Measurements (requires GPS Option MS2090A-0031)
MS27201A-xxxx-0098	Standard Calibration to ISO17025 and ANSI/NCCL Z540-1 (xxxx is the frequency option number)
MS27201A-xxxx-0099	Premium Calibration to ISO17025 and ANSI/NCCL Z540-1 plus test data (xxxx is the frequency option number)
Supporting Software	
MX280005A	Vector Signal Analysis PC Software
MX280001A	Remote Spectrum Monitor Vision Software
MS27201A	PC Remote User Interface

For a full list of all accessories for the Remote Spectrum Monitor MS27201A, please refer to the Technical Data Sheet (P/N 11410-02833).

• **United States**

Anritsu Americas Sales Company

450 Century Parkway, Suite 190, Allen, TX 75013 U.S.A.
Phone: +1-800-Anritsu (1-800-267-4878)

• **Canada**

Anritsu Electronics Ltd.

700 Silver Seven Road, Suite 120, Kanata,
Ontario K2V 1C3, Canada
Phone: +1-613-591-2003
Fax: +1-613-591-1006

• **Brazil**

Anritsu Eletronica Ltda.

Praça Amadeu Amaral, 27 - 1 Andar
01327-010 - Bela Vista - Sao Paulo - SP, Brazil
Phone: +55-11-3283-2511
Fax: +55-11-3288-6940

• **Mexico**

Anritsu Company, S.A. de C.V.

Bldv Miguel de Cervantes Saavedra #169 Piso 1, Col. Granada
Mexico, Ciudad de Mexico, 11520, MEXICO
Phone: +52-55-4169-7104

• **United Kingdom**

Anritsu EMEA Ltd.

200 Capability Green, Luton, Bedfordshire, LU1 3LU, U.K.
Phone: +44-1582-433200
Fax: +44-1582-731303

• **France**

Anritsu S.A.

12 avenue du Québec, Immeuble Goyave,
91140 VILLEBON SUR YVETTE, France
Phone: +33-1-60-92-15-50

• **Germany**

Anritsu GmbH

Nemetschek Haus, Konrad-Zuse-Platz 1,
81829 München, Germany
Phone: +49-89-442308-0
Fax: +49-89-442308-55

• **Italy**

Anritsu S.r.l.

Spaces Eur Arte, Viale dell'Arte 25, 00144 Roma, Italy
Phone: +39-6-509-9711

• **Sweden**

Anritsu AB

Kistagången 20 B, 2 tr, 164 40 Kista, Sweden
Phone: +46-8-534-707-00

• **Finland**

Anritsu AB

Technopolis Aviapolis, Teknobulevardi 3-5 (D208.5.),
FI-01530 Vantaa, Finland
Phone: +358-20-741-8100

• **Denmark**

Anritsu A/S

c/o Regus Winghouse, Ørestads Boulevard 73, 4th floor,
2300 Copenhagen S, Denmark
Phone: +45-7211-2200

• **Russia**

Anritsu EMEA Ltd.

Representation Office in Russia

Tverskaya str. 16/2, bld. 1, 7th floor., Moscow, 125009, Russia
Phone: +7-495-363-1694
Fax: +7-495-935-8962

• **Spain**

Anritsu EMEA Ltd.

Representation Office in Spain

Paseo de la Castellana, 141. Planta 5, Edificio Cuzco IV
28046, Madrid, Spain
Phone: +34-91-572-6761

• **Austria**

Anritsu EMEA GmbH

Am Belvedere 10, A-1100 Vienna, Austria
Phone: +43-(0)1-717-28-710

• **United Arab Emirates**

Anritsu EMEA Ltd.

Anritsu A/S

Office No. 164, Building 17, Dubai Internet City
P. O. Box - 501901, Dubai, United Arab Emirates
Phone: +971-4-3758479

• **India**

Anritsu India Private Limited

6th Floor, Indiqueb ETA, No.38/4, Adjacent to EMC2,
Doddanekundi, Outer Ring Road, Bengaluru - 560048, India
Phone: +91-80-6728-1300
Fax: +91-80-6728-1301

• **Singapore**

Anritsu Pte. Ltd.

11 Chang Charn Road, #04-01, Shriro House, Singapore 159640
Phone: +65-6282-2400
Fax: +65-6282-2533

• **Vietnam**

Anritsu Company Limited

16th Floor, Peakview Tower, 36 Hoang Cau Street, O Cho Dua Ward,
Dong Da District, Hanoi, Vietnam
Phone: +84-24-3201-2730

• **P.R. China (Shanghai)**

Anritsu (China) Co., Ltd.

Room 2701-2705, Tower A, New Caohejing International
Business Center No. 391 Gui Ping Road Shanghai, 200233, P.R. China
Phone: +86-21-6237-0898
Fax: +86-21-6237-0899

• **P.R. China (Hong Kong)**

Anritsu Company Ltd.

Unit 1006-7, 10/F., Greenfield Tower, Concordia Plaza,
No. 1 Science Museum Road, Tsim Sha Tsui East,
Kowloon, Hong Kong, P.R. China
Phone: +852-2301-4980
Fax: +852-2301-3545

• **Japan**

Anritsu Corporation

8-5, Tamura-cho, Atsugi-shi, Kanagawa, 243-0016 Japan
Phone: +81-46-296-6509
Fax: +81-46-225-8352

• **Korea**

Anritsu Corporation, Ltd.

5FL, 235 Pangyojeok-ro, Bundang-gu, Seongnam-si,
Gyeonggi-do, 13494 Korea
Phone: +82-31-696-7750
Fax: +82-31-696-7751

• **Australia**

Anritsu Pty. Ltd.

Unit 20, 21-35 Ricketts Road, Mount Waverley, Victoria 3149, Australia
Phone: +61-3-9558-8177
Fax: +61-3-9558-8255

• **Taiwan**

Anritsu Company Inc.

7F, No. 316, Sec. 1, NeiHu Rd., Taipei 114, Taiwan
Phone: +886-2-8751-1816
Fax: +886-2-8751-1817

List Revision Date: 20210610



Anritsu utilizes recycled paper and environmentally conscious inks and toner.



© Anritsu All trademarks are registered trademarks of their respective owners. Data subject to change without notice. For the most recent specifications visit: www.anritsu.com

11410-02861, Rev. C Printed in United States 2022-02
©2022 Anritsu Company. All Rights Reserved.